

DERBI-TITE SENTINEL® DRIP EDGE

DESCRIPTION

DERBI-TITE SENTINEL® Drip Edge combines custom engineering and superior performance with an attractive appearance. The patented design of the extruded aluminum anchor bar securely terminates the membrane, providing superior protection.

ADVANTAGES

- ▶ Non-penetrating design eliminates the need for stripping-in or heat welding that are typical with other roof edge systems
- ▶ Sizes range from 3" up to 7 1/2" face heights to accommodate multiple nailers and coverage requirements.
- ▶ Watertight integrity is not compromised by improper flashing procedures, failed adhesives or lap sealants
- ▶ FM approved for wind uplift protection
- ▶ Carefully designed and ANSI/SPRI/ES-1 Tested to comply with the International Building Code

COLORS & FINISHES

Express, standard and premium colors and finishes are available to meet your job requirements. Includes a 30-year Kynar 500 finish warranty on coil-coated standard colors. Custom colors are also available. For the most accurate color representation contact Performance Roof Systems to request a paint chip.

10 EXPRESS COLORS FOR QUICK SHIPPING

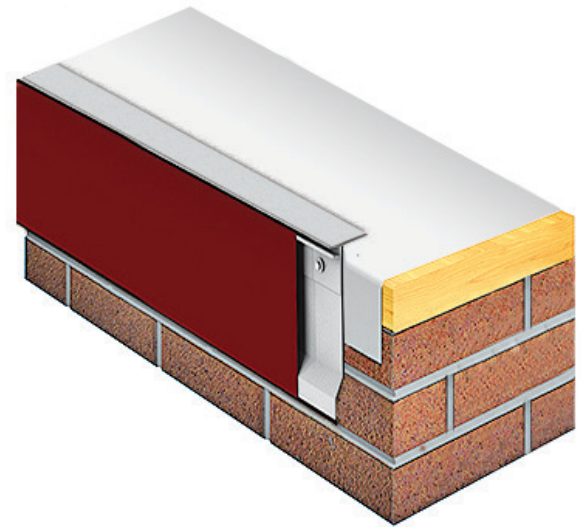
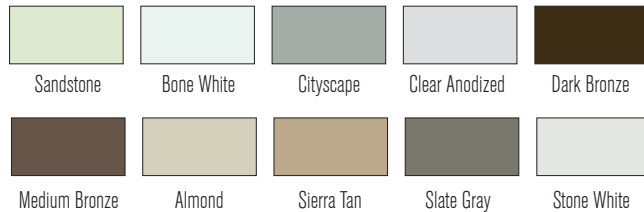

TYPICAL INSTALLATION

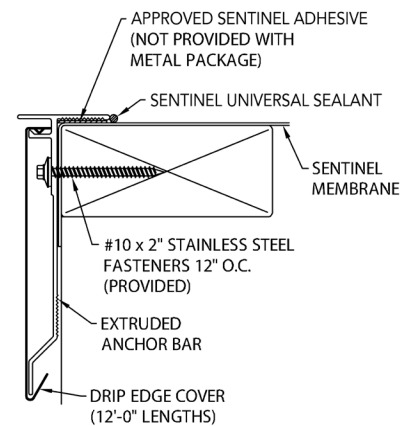

TECHNICAL SERVICES

Engineering and shop drawings are available from the factory. Product samples, detail sheets, color chips and color charts are ready for your submittal package. Long form specifications and CAD details are available on our web site. For personal assistance with questions or submittals, contact your local representative or call Performance Roof Systems.