

SENTINEL® PVC DRIP EDGE

DESCRIPTION

SENTINEL® PVC Drip Edge systems are engineered with an interlocking, concealed splice plate designed to prevent splice plate migration under the fascia panels. SENTINEL® PVC Drip Edge is manufactured in 12 foot lengths with pre-punched fastening holes for precise fastener placement. Factory fabricated miters, scuppers and drainage accessories help eliminate the need for field fabrication.

PRODUCT SELECTION

SENTINEL® PVC Drip Edge is a factory-fabricated coated metal edge system that substantially reducing installation time. Drip Edge is available in the following sizes: 2½", 3", 4", 6"

SENTINEL® PVC Skirted Drip Edge is a factory-fabricated coated metal edge system comes with a factory applied, wide PVC flashing strip to help save labor installation costs in the field. Skirted Drip Edge is available in the following sizes: 4½" and 6"

ADVANTAGES

- ▶ Manufactured in 12 ft lengths with pre-punched holes that are slotted to allow for proper thermal movement
- ▶ Pre-punched holes and factory-welded membrane flashing for fast installation
- ▶ FM approved for wind uplift protection
- ▶ Carefully designed and ANSI/SPRI/ES-1 tested to comply with International Building Code

COLORS & FINISHES

Express, standard and premium colors and finishes are available to meet your job requirements. Includes a 30-year Kynar 500 finish warranty on coil-coated standard colors. Custom colors are also available. For the most accurate color representation contact Performance Roof Systems to request a paint chip.

10 EXPRESS COLORS FOR QUICK SHIPPING

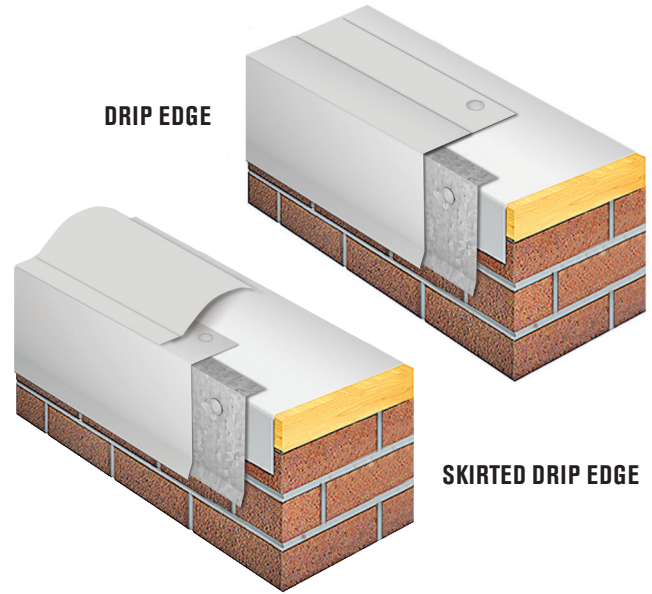

TECHNICAL DRAWINGS

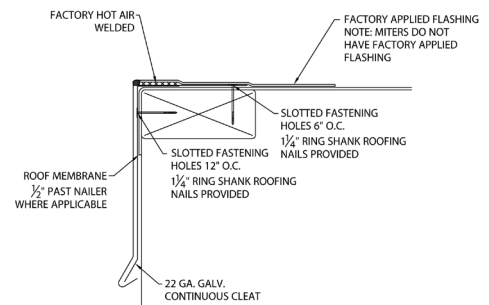

TECHNICAL SERVICES

Engineering and shop drawings are available from the factory. Product samples, detail sheets, color chips and color charts are ready for your submittal package. Long form specifications and CAD details are available on our web site. For personal assistance with questions or submittals, contact your local representative or call Performance Roof Systems.